

CedIFER
 -SAE 4140
 -TEMPERAR E REVENIR :
 44-46HrC
 -OXIDAR PRETO

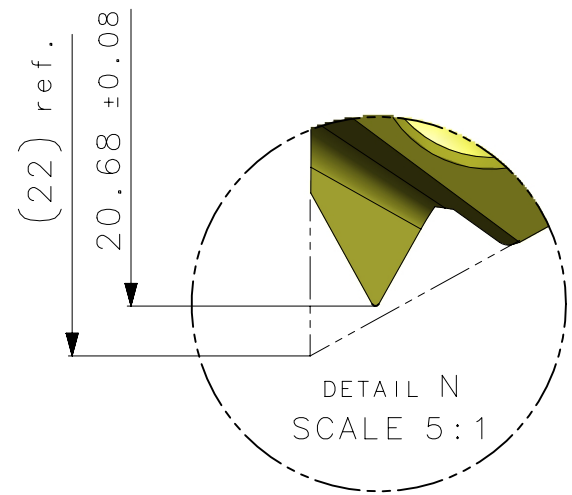

A3
100
90
80
70
60
50
40
30
20
10
0

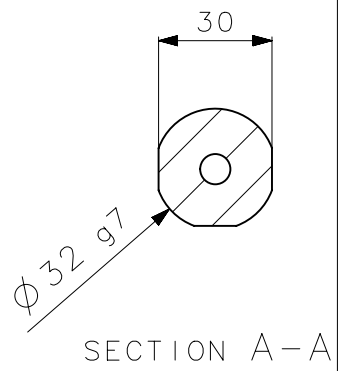
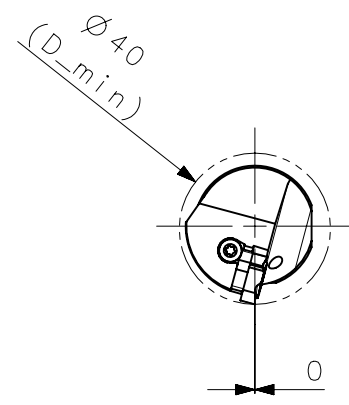
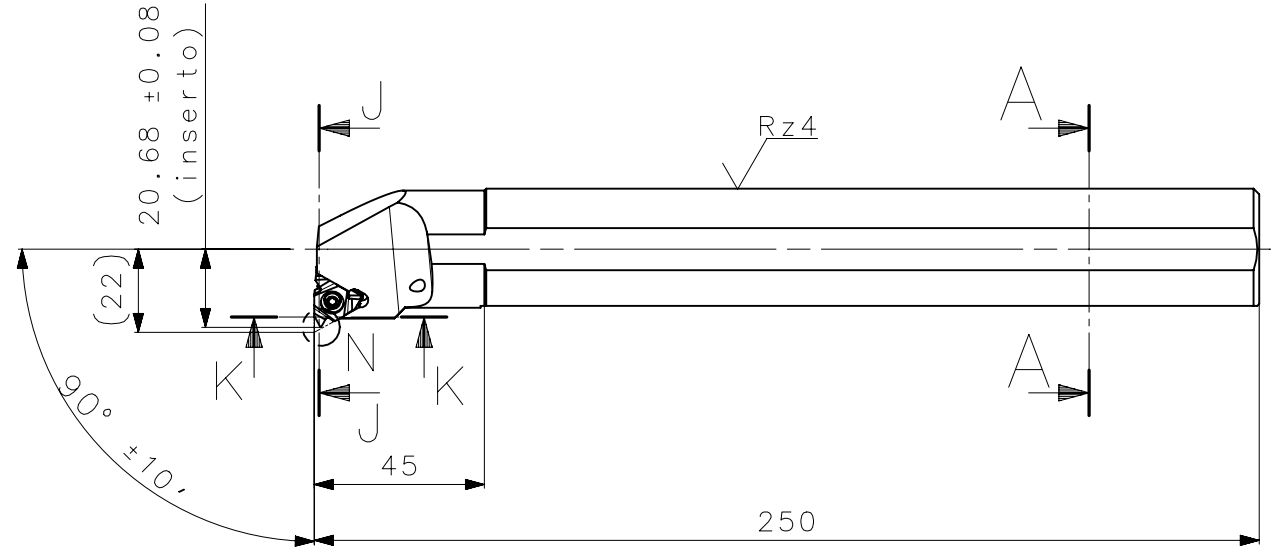
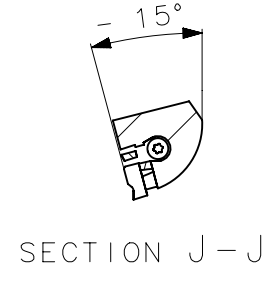
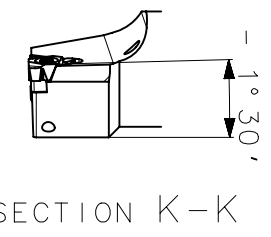
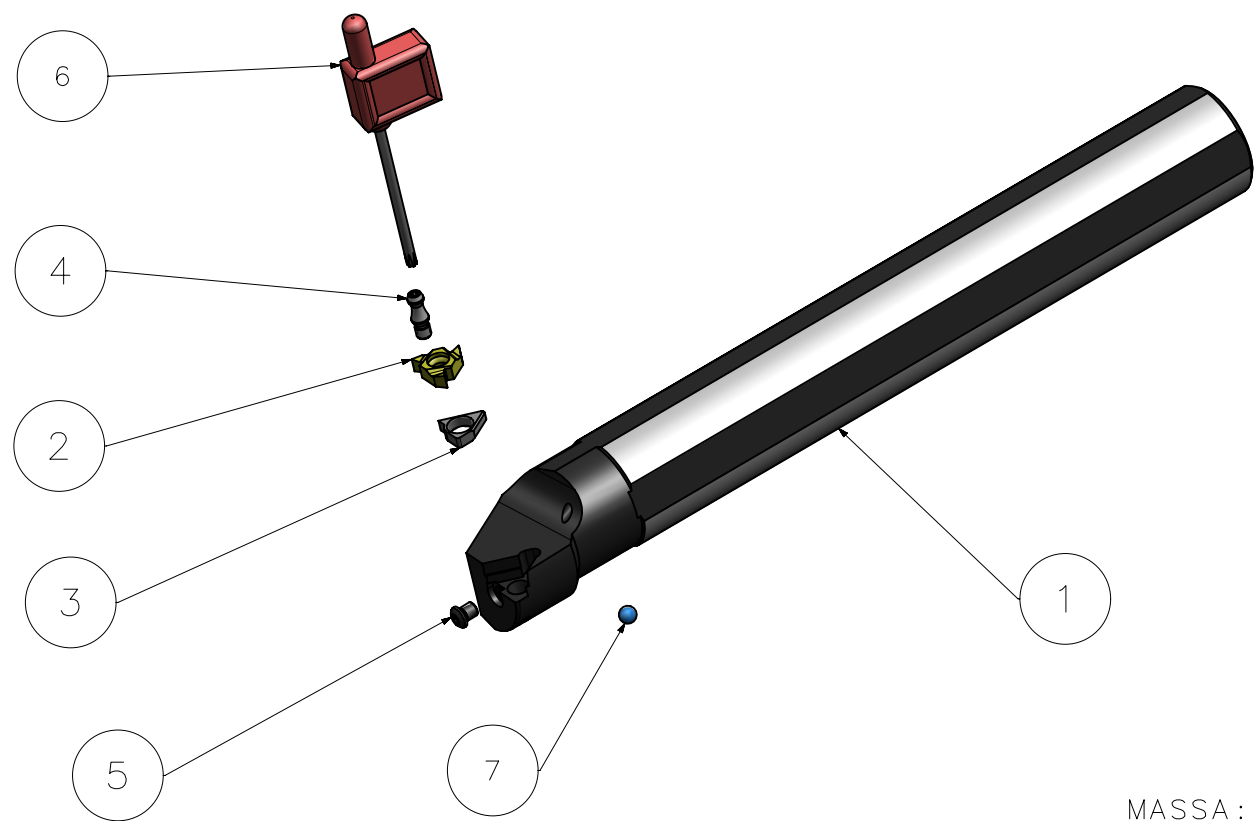

MASSA: 1.37kg

Item	Quant.	Descricao	Material	Obs
7	1	ESFERA_3_16_R1664KF3216	std.	
6	1	CHAVE_TORX_T9_R1664KF3216	HARD TOOLS	
5	1	PARAF_CALC0_551203201_R1664KF3216	HARD TOOLS	
4	1	PARAF_TORX_551302601_R1664KF3216	HARD TOOLS	
3	1	CALCO_532236110_R1664KF3216	HARD TOOLS	
2	1	INSERTO_WT16IRG60_R1664KF3216	W WELLER	
1	1	CORPO	SAE 4140	

ACABAMENTO DE SUPERFICIES	DIN 1302	DIN 3141
Rz1		
Rz4		
Rz16		
Rz63		
M.Bruto		

Obs: Quebrar cantos vivos
 Ref. do cliente(Produto):
 Ref. do cliente(ferramenta):
 Substitui:
 Cliente:

CedIFER
 ABNT NB-8
 Data: 28/07/10
 Nome: MARCOS
 Verificado: 28/07/10
 PEDRO
 Aprovado: 28/07/10
 RENATO
 Escala: 1:1
 Folha: 1 - 3
 Titulo :
 BARRA MAXI-THREAD STD.
 (DESENHO DO CONJUNTO)
 Des. N. :
 D_R1664KF3216
 Formato:
 A3

SÍMBOLOS GEOMÉTRICOS			